

485E 486E 488E

FORKLIFTS

SPECIFICATIONS

CONSTRUCTION EQUIPMENT DIVISION JD

Engine 485E / 486E / 488E

Type.....	John Deere 4045D – Naturally Aspirated
Rated power @ 2,200 rpm	73 SAE net hp (54.4 kW) / 78 SAE gross hp (58.2 kW)
Cylinders.....	4
Displacement.....	276 cu. in. (4.524 L)
Fuel consumption, typical	1.1 to 1.9 gal./hr. (4.2 to 7.2 L/h)
Torque rise, net.....	26 percent
Maximum net torque.....	220 lb.-ft.
Lubrication.....	pressure system with spin-on filter and cooler
Air cleaner	dual stage, dry type with safety element, evacuator valve, and prescreener
Electrical system.....	12 volt with 65-amp alternator
Cooling fan	sucker type, 1:1 speed ratio

Transmission

Type.....	four-speed, helical-cut gear, collar shift transmission synchronized in all gears with hydraulic reverser	
Torque converter.....	single stage, dual phase with 2.63:1 stall ratio, 11 in. (280 mm) diameter	
Travel speeds (maximum)	<i>Forward</i>	<i>Reverse</i>
Gear 1	4.3 mph (6.9 km/h)	3.9 mph (6.3 km/h)
Gear 2	7.1 mph (11.4 km/h)	6.4 mph (10.3 km/h)
Gear 3	17.2 mph (27.7 km/h)	15.4 mph (24.8 km/h)
Gear 4	24.2 mph (38.9 km/h)	21.6 mph (34.7 km/h)

Final Drives

Type.....	heavy-duty, inboard planetary final drives evenly distribute shock loads over three gears
-----------	---

Brakes (conform to ANSI B56.6 – 1992)

Service brakes	hydraulic multi wet disc, mounted inboard, self adjusting and self equalizing
Parking and secondary brake.....	spring-applied, hydraulically released multi wet disc, independent of service brakes, switch-operated electrical control, self engaging with engine shutdown

Capacities

	<i>Fill/Change</i>
Fuel tank (with ground level fueling)	21.5 gal. (81 L)
Engine coolant	3.9 gal. (14.8 L)
Engine oil including filter.....	9 qt. (8.5 L)
Torque converter and transmission	15 qt. (14 L)
Hydraulic system	12.5 gal. (47.3 L)
Rear axle	3.5 gal. (13 L)
Mechanical-rear-wheel-drive axle.....	2.3 gal. (8.5 L)

Steering (conforms to ANSI B56.6 – 1992)

Type.....	hydrostatic power steering
Non-powered steering axle	
Curb turning radius	
With brakes	11 ft. 9 in. (3.57 m)
Without brakes	13 ft. 3 in. (4.04 m)
Clearance circle	
With brakes	23 ft. 6 in. (7.16 m)
Without brakes	26 ft. 6 in. (8.08 m)
Powered steering axle, mechanical-rear-wheel-drive	
Curb turning radius	
With brakes	10 ft. 11 in. (3.34 m)
Without brakes	13 ft. 8 in. (4.17 m)
Clearance circle	
With brakes	21 ft. 10 in. (6.65 m)
Without brakes	27 ft. 4 in. (8.33 m)
Steering wheel turns, stop to stop.....	3
Axle oscillation, stop to stop.....	22 degrees
Axle ratings (SAE J43)	
Front.....	17,340 lb. (7865 kg)
Rear.....	12,610 lb. (5720 kg)

Hydraulic System 485E / 486E / 488E

System	open center
Pressure	2,500 psi (17 237 kPa)
Pump	gear type
Flow @ 2,200 rpm.....	25 gpm (94.6 L/min.)
Filter, return oil.....	10 micron, spin-on replaceable element
Controls	priority valve for steering; three-lever, three-function valve for mast

Cylinders

	<i>Bore</i>	<i>Stroke</i>	<i>Rod</i>
Steering			
Standard axle (1)	1.97 in. (50 mm)	9.49 in. (241 mm)	0.98 in. (25 mm)
Mechanical-rear-wheel-drive axle (1).....	2.56 in. (65 mm)	8.27 in. (210 mm)	1.42 in. (36 mm)

Tires 485E 486E 488E

Non-powered rear axle			
Rear.....	19.5L-24, 10 PR R4	19.5L-24, 10 PR R4	19.5L-24, 10 PR R4
Front.....	11L-16, 12 PR F3	11L-16, 12 PR F3	11L-16, 12 PR F3
Mechanical-rear-wheel-drive			
Rear.....	19.5L-24, 10 PR R4	19.5L-24, 10 PR R4	19.5L-24, 10 PR R4
Front.....	12.5/80-18, 10 PR	12.5/80-18, 10 PR	12.5/80-18, 10 PR
Wheel tread			
Drive			
19.5L-24, 10 PR R4.....	65.5 in. (1665 mm)	65.5 in. (1665 mm)	65.5 in. (1665 mm)
Steering			
11L-16, 12 PR F3.....	68.8 in. (1748 mm)	68.8 in. (1748 mm)	68.8 in. (1748 mm)
12.5/80-18, 10 PR.....	73.4 in. (1865 mm)	73.4 in. (1865 mm)	73.4 in. (1865 mm)
Width across tires			
Drive			
19.5L-24, 10 PR R4.....	86.0 in. (2185 mm)	86.0 in. (2185 mm)	86.0 in. (2185 mm)
Steering			
11L-16, 12 PR F3.....	80.6 in. (2047 mm)	80.6 in. (2047 mm)	80.6 in. (2047 mm)
12.5/80-18, 10 PR.....	86.4 in. (2195 mm)	86.4 in. (2195 mm)	86.4 in. (2195 mm)

SAE Operating Weights

14-ft. (4.27 m) 6,000-lb. (2720 kg)			
See-Thru Mast.....		12,510 lb. (5670 kg)	
14-ft. (4.27 m) 6,000-lb. (2720 kg)			
Free-Lift Mast.....		12,560 lb. (5700 kg)	
14-ft. (4.27 m) 8,000-lb. (3628 kg)			
See-Thru Mast.....			14,560 lb. (6600 kg)
21-ft. (6.40 m) 6,000-lb. (2720 kg)			
Free-Lift Mast.....		13,510 lb. (6130 kg)	
21-ft. 6-in. (6.55 m) 5,000-lb. (2268 kg) See-Thru Mast.....		13,210 lb. (5990 kg)	
21-ft. 6-in. (6.55 m) 6,000-lb. (2720 kg) See-Thru Mast.....		13,360 lb. (6060 kg)	
21-ft. 6-in. (6.55 m) 8,000-lb. (3628 kg) See-Thru Mast.....			15,560 lb. (7070 kg)
Mechanical-rear-wheel-drive adds.....	240 lb. (110 kg)	240 lb. (110 kg)	240 lb. (110 kg)

Tines (Shipping Weights)

Two 4-ft. (1.22 m) pallet tines.....	290 lb. (132 kg)	310 lb. (141 kg)	396 lb. (180 kg)
--------------------------------------	------------------	------------------	------------------

Operating Information	485E	486E	488E
Maximum lift capacity at ground level	5,000 lb. (2268 kg)	6,000 lb. (2721 kg)	8,000 lb. (3628 kg)
Lift capacity @ full height*			
14-ft. (4.27 m) Free Lift	6,000 lb. (2721 kg)		
14-ft. (4.27 m) See Thru	6,000 lb. (2721 kg)		8,000 lb. (3628 kg)
21-ft. (6.40 m) Free Lift	2,500 lb. (1134 kg)		
21-ft. 6-in. (6.55 m) See Thru	2,500 lb. (1134 kg)		2,500 lb. (1134 kg)
Rate of lift @ 2,350 engine rpm and maximum load			
14-ft. (4.27 m) Free Lift	72 fpm (22 m/min.)		
14-ft. (4.27 m) See Thru	62 fpm (19 m/min.)		62 fpm (19 m/min.)
21-ft. (6.40 m) Free Lift (Stages 1 and 2)	72 fpm (22 m/min.)		
21-ft. 6-in. (6.55 m) See Thru	94 fpm (29 m/min.)	94 fpm (29 m/min.)	94 fpm (29 m/min.)
Side shift, right and left of center	3 in. (76 mm)	3 in. (76 mm)	3 in. (76 mm)

*Measured at 24 in. (610 mm) from heel of fork with load centered.

Dimensions

A Overall height, mast raised			
14 ft. (4.27 m) mast	200 in. (5080 mm)		200 in. (5080 mm)
21 ft. (6.40 m) mast	284 in. (7220 mm)		
21 ft. 6 in. (6.55 m) mast	285 in. (7240 mm)		287 in. (7290 mm)
B Overall height, mast closed			
14 ft. (4.27 m) mast	120 in. (3050 mm)		120 in. (3050 mm)
21 ft. (6.40 m) mast	122 in. (3100 mm)		
21 ft. 6 in. (6.55 m) mast	120 in. (3050 mm)		126 in. (3200 mm)
C Height, top of FOPS	101.5 in. (2580 mm)	101.5 in. (2580 mm)	101.5 in. (2580 mm)
D Maximum fork height, forks horizontal			
14 ft. (4.27 m) mast	171 in. (4340 mm)		171 in. (4340 mm)
21 ft. (6.40 m) mast	255 in. (6480 mm)		
21 ft. 6 in. (6.55 m) mast	256 in. (6500 mm)		256 in. (6500 mm)
E Wheelbase			
Two-wheel-drive	82.7 in. (2100 mm)	82.7 in. (2100 mm)	82.7 in. (2100 mm)
Four-wheel-drive	83.3 in. (2115 mm)	83.3 in. (2115 mm)	83.3 in. (2115 mm)
F Overall length			
5,000-lb. (2268 kg) mast	200 in. (5080 mm)		
6,000-lb. (2721 kg) mast	200 in. (5080 mm)		
8,000-lb. (3628 kg) mast			203 in. (5160 mm)
G Length, less forks			
5,000-lb. (2268 kg) mast	150 in. (3810 mm)		
6,000-lb. (2721 kg) mast	150 in. (3810 mm)		
8,000-lb. (3628 kg) mast			153 in. (3880 mm)
H Reach	36.2 in. (920 mm)	36.2 in. (920 mm)	36.2 in. (920 mm)
I Degrees tilt, forward	30 degrees	30 degrees	30 degrees
J Degrees tilt, rearward	10 degrees	10 degrees	10 degrees
K Ground clearance	15 in. (381 mm)	15 in. (381 mm)	15 in. (381 mm)
L Obstacle clearance, mast	10.5 in. (267 mm)	10.5 in. (267 mm)	10.5 in. (267 mm)
M Tire static radius	23.7 in. (602 mm)	23.7 in. (602 mm)	23.7 in. (602 mm)

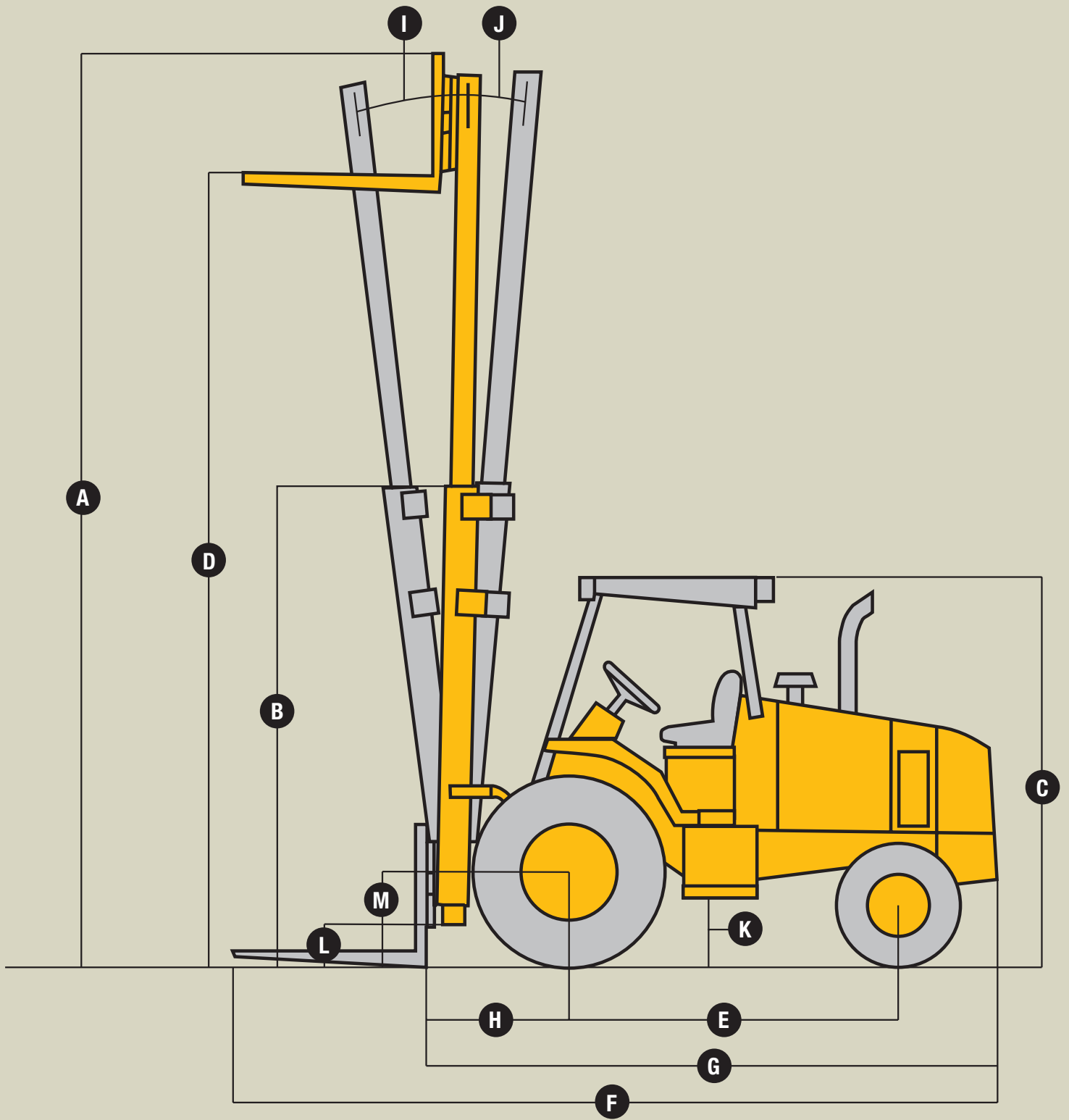

Additional Equipment

Key: ● Standard equipment ▲ Optional or special equipment

*See your John Deere dealer for further information.

485 486 488 Engine

- ● ● John Deere Model 4045D, 73 SAE net hp (54.4 kW)
- ● ● Naturally aspirated, isolation mounted
- ● ● Spin-on engine oil and fuel filters
- ● ● Antifreeze, -34°F (-37°C)
- ● ● Coolant recovery tank
- ● ● Serpentine belt with automatic belt tensioner
- ● ● Sucker-type cooling fan
- ● ● Dual-stage, dry-type air cleaner with safety element, evacuator valve, and prescreener
- ▲ ▲ ▲ Engine coolant heater, 1,000 watts*

Power Train

- ● ● Transmission with power-shift reverser and torque converter: Fully synchronized four forward and four reverse speeds / Isolation mounted to mainframe
- ● ● Transmission oil cooler
- ● ● Vertical spin-on transmission filter
- ● ● Electrical forward-neutral-reverse control lever with neutral safety switch interlock
- ● ● Electric clutch cutoff on gearshift lever
- ● ● Differential lock, electric switch foot activated
- ● ● Planetary final drives
- ● ● Hydraulic service brakes (conform to ANSI B56.6 - 1992): Inboard, multi wet disc, self adjusting and self equalizing
- ● ● Parking brake with electric switch control (conforms to ANSI B56.6 - 1992): Spring applied, hydraulically released multi wet disc / Independent of service brakes
- ● ● Hydrostatic power steering (conforms to ANSI B56.6 - 1992)
- ▲ ▲ ▲ Non-powered rear axle
- ▲ ▲ ▲ Mechanical-four-wheel-drive: Electric on/off control / Sealed axle
- ● ● Tires: 11L-16, 12 PR F3 steering tires / 12.5/80-18, 10 PR traction steering tires / 19.5L-24, 10 PR R4 drive tires

485 486 488 Hydraulic System

- ● ● Gear pump, 25 gpm (94.6 L/min.) at 2,200 rpm
- ● ● Open-center system
- ● ● Independent hydraulic reservoir
- ● ● Hydraulic oil cooler
- ● ● O-ring face seal connections
- ● ● 10-micron vertical spin-on filter
- ● ● Circuit relief valve protection
- ● ● Sucker-type mast control

Electrical

- ● ● 12-volt system
- ● ● 65-amp alternator
- ● ● Positive terminal battery cover
- ● ● Blade-type multi-fused circuits
- ● ● By-pass start safety cover on starter
- ▲ ▲ ▲ Single battery with 160-min. reserve capacity and 625 CCA
- ▲ ▲ ▲ Dual batteries with 320-min. reserve capacity and 1,250 CCA

Lights

- ● ● Two front halogen driving/work lights, 32,500 candlepower each
- ● ● One rear halogen work light, 32,500 candlepower
- ● ● One rear stop and taillight
- ● ● Two rear reflectors
- ▲ ▲ ▲ Rotating beacon*

Operator's Station

- ● ● Four-post FOPS (conforms to ANSI B56.6 - 1992 and SAE J154)
- ● ● Left- and right-side access
- ● ● Slip-resistant steps and ergonomically located handholds
- ● ● Built-in Operator's Manual storage compartment with manual
- ● ● Interior rearview mirror
- ● ● Right-foot throttle
- ● ● Horn (conforms to SAE J1446)
- ● ● Key start with electric fuel shutoff
- ● ● Hourmeter, electric
- ● ● Fuel gauge, illuminated electric

485 486 488 Operator's Station (continued)

- ● ● Monitor system: With visual warning indicators for engine air filter restriction, alternator, torque converter oil temperature, mechanical-rear-wheel-drive on/off and seat belt / With visual indicator and audible warning for engine coolant temperature, engine oil pressure, and parking brake on/off

- ▲ ▲ ▲ Seat, suspension, and seat belt: Non-suspension: fore/aft adjustable vinyl seat with 3-in. (76 mm) seat belt and retractor / Suspension: fore/aft adjustable vinyl seat with flip-up armrests, backrest angle adjustment, weight adjustment, and 3-in. (76 mm) seat belt and retractor

Overall Vehicle

- ● ● One-piece unitized construction mainframe
- ● ● Vehicle tie-downs, two mid-frame and two rear
- ● ● Fuel tank, 21.5 gal. (81 L), ground level fueling
- ● ● Reverse warning alarm (conforms to SAE J1446): Switchable to 97dB(A) or 111 dB(A)
- ● ● Enclosed safety guard on engine cooling fan
- ● ● Vandal protection for instrument panel, fuel tank, and hydraulic reservoir
- ● ● Hinged engine side shields, lockable
- ● ● Fenders
- ▲ ▲ ▲ Cold weather starting aid*
- ▲ ▲ ▲ SMV emblem*
- ▲ ▲ ▲ Cab panels*

Attachments

- ▲ ▲ ▲ Masts, with 30-degree forward tilt, 10-degree rearward tilt, and sideshift: 5,000-lb., 21-ft. 6-in. See Thru, slider / 6,000-lb., 14 ft. See Thru slider / 6,000-lb., 14-ft. Free Lift, roller / 6,000-lb., 21-ft. 6-in. See Thru, slider / 6,000-lb., 21-ft. Free Lift, roller / 8,000-lb., 14-ft. See Thru, roller / 8,000-lb., 21-ft. 6-in. See Thru, roller
- ▲ ▲ ▲ Forks: 5,000 lb., 48 in. / 6,000 lb., 48 in. / 8,000 lb., 48 in.
- ▲ ▲ ▲ Counterweights: For 5,000- or 6,000-lb. mast / For 8,000-lb. mast

Control Owning and Operating Costs

Total Repair Cost Management (TRCM) is part of John Deere's proactive, fix-before-fail strategy on machine maintenance that will help control costs, increase profits, and reduce stress. Included in this comprehensive lineup of ongoing programs and services are:

OilScan® Plus program – tells you what's going on inside *all* of your machine's major components so you'll know if there's a problem *before* you see a decline in performance. OilScan Plus oil analysis is included in most SECURE®-Extended warranty and preventive-maintenance agreements.

Component life-cycle data – gives you vital information on the projected life span of components and lets you make informed decisions on machine maintenance by telling you approximately how many hours of use you can expect from an engine, transmission, or hydraulic pump. This information can be used to preempt catastrophic downtime by servicing major components at about 80 percent of their life cycle.

Preventive Maintenance (PM) agreements – give you a fixed cost for maintaining a machine for a given period of time. They also help you avoid downtime by ensuring that critical maintenance work

gets done right and on schedule. On-site preventive maintenance service performed where and when you need it helps protect you from the expense of catastrophic failures and lets you avoid waste-disposal hassles.

SECURE-Extended warranty – gives you a fixed cost for machine repairs for a given period of time so you can effectively manage costs. Whether you work in a severe-service setting or just want to spread the risk of doing business, this is a great way to custom-fit coverage for your operation. And a SECURE-Extended contract also travels well because it's backed by John Deere and is honored by *all* Deere construction dealers.

Customer Support Advisors (CSAs) – Deere believes the CSA program lends a *personal* quality to Total Repair Cost Management. Certified CSAs have the knowledge and skills for helping make important decisions on machine maintenance and repair. Their mission is to help you implement a plan that's right for *your* business and take the burden of machine maintenance off your shoulders.



Net engine power is with standard equipment including air cleaner, exhaust system, alternator, and cooling fan, at standard conditions per SAE J1349 and DIN 70 020, using No. 2-D fuel at 35 API gravity. No derating is required up to 6,000-ft. (1800 m) altitude. Gross power is without cooling fan.

Specifications and design subject to change without notice. Wherever applicable, specifications are in accordance with SAE standards. Except where otherwise noted, these specifications are based on a unit with 19.5L-24, 10 PR R4 rear tires; and 11L-16, 12 PR F3 front tires.

